

# JBL 7130 INSTALLATION AND SERVICE MANUAL

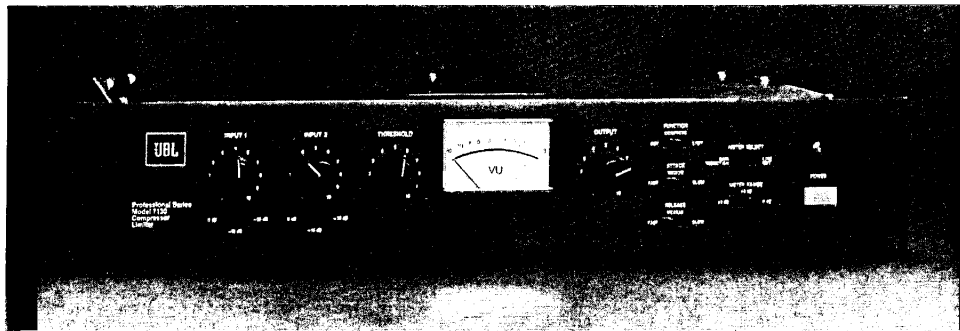

## Owners Instructions

### Architectural Specifications

The 7130 compressor/limiter shall have an output capacity of +18 dBm from 20 Hz-20 kHz,  $\pm 1$  dB and total harmonic distortion shall be less than 0.25% to +18 dBm, 20 Hz-20 kHz in either the compression or limiting mode with up to 30 dB of gain reduction.

The unit shall accept high impedance, unbalanced microphones. The microphone preamplifier circuitry shall employ field effect transistors for low noise. The compressor shall be capable of any combination of line-line, mic-mic, or line-mic operation. Balanced inputs shall be possible by using optional input transformers. Outputs shall be transformer isolated or direct for connection to a balanced or unbalanced 600  $\Omega$  line.

The compressor/limiter shall be equipped with a selector switch to place the unit in one of three modes of operation: **OUT**, **COMPRESS**, or **LIMIT**. The normal threshold of compression shall be 0 dBm output. An input level control shall vary the gain when the selector switch is in the **OUT** mode. It shall also determine the relative threshold when the unit is in the **COMPRESS** or **LIMIT** mode. Two switches shall be provided for the selection of three release times and three attack times.

The unit shall be equipped with a meter, governed by a function selector switch, which indicates amount of compression or output level in dB. When indicating output level, three ranges shall be selectable so that 0 VU on the meter corresponds to an output level of 0 dBm, +4 dBm, or +8 dBm, unbalanced, and +2 dBm, +6 dBm, or +10 dBm balanced output. The unit shall operate on 120/240 V AC, 50/60 Hz.

The unit shall be JBL Model 7130.

JBL continually engages in research related to product improvement. New materials, production methods and design refinements are introduced into existing products without notice as to routine expression of the philosophy. For this reason, any current JBL product may differ in some respects from its published description, but will always equal or exceed the original design specifications unless otherwise stated.

### PRODUCT SPECIFICATIONS

#### Maximum Gain

Direct Input (Unbalanced) <sup>1</sup>	
Line	30 dB, high Z
Microphone	62 dB, high Z
Balanced Input <sup>1</sup>	
Line with 5195 Transformer	84 dB, low Z
Microphone with 5901 Transformer	30 dB, high Z

#### Output Characteristics

Output Impedance	
Direct	40-80 $\Omega$ , unbalanced (20 Hz-20 kHz)
Balanced	400-600 $\Omega$ (20-20 kHz)
Maximum Output Level	+18 dBm

#### Input Characteristics

Input Impedance	
Direct Input (Unbalanced)	
Line	15 k $\Omega$
Microphone	51 k $\Omega$
Balanced Input	
Line with 5195 Transformer	15 k $\Omega$
Microphone with 5901 Transformer	800 $\Omega$

#### Normal Input Level

Direct Input (Unbalanced) <sup>1</sup>	
Line	170 mV RMS minimum (-13.5 dBm)
Microphone	
Input Pad 0	5.4 mV RMS minimum (-41.5 dBm) <sup>1</sup>
Input Pad -15	30 mV RMS minimum (-28.1 dBm)
Input Pad -30	163 mV RMS minimum (-13.1 dBm)
Balanced Input <sup>1</sup>	
Line with 5195 Transformer	190 mV RMS minimum (-12.5 dBm)
Microphone <sup>1</sup>	
Input Pad 0	0.38 mV RMS minimum (-66.2 dBm)
Input Pad -15	2.15 mV RMS minimum (-51.2 dBm)
Input Pad -30	11.8 mV RMS minimum (-36.2 dBm)

#### Input Overload<sup>2</sup>

Direct Input (Unbalanced)	
Line	11.5 V RMS (+23.5 dBm)
Microphone	
Input Pad 0	120 mV RMS (-16.2 dBm)
Input Pad -15	650 mV RMS (-1.2 dBm)
Input Pad -30	3.65 V RMS (+13.5 dBm)
Balanced Input	
Line with 5195 Transformer	3.32 V (+13.5 dBm)
Microphone	
Input Pad 0	9.2 mV RMS (-39.5 dBm)
Input Pad -15	53 mV RMS (-24.5 dBm)
Input Pad -30	270 mV RMS (-9.5 dBm)

#### Frequency Response

Direct Output <sup>1</sup>	
Direct Input	
Line	+0, -1 dB, 10 Hz-50 kHz
Microphone	+0.25, -1 dB, 10 Hz-47 kHz
Balanced Input <sup>1</sup>	
Line with 5195 Transformer	+1, -2 dB, 30 Hz-20 kHz
Microphone with 5901 Transformer	+1, -2 dB, 30 Hz-20 kHz
Balanced Output	
Direct Input <sup>1</sup>	
Line	+0, -1 dB, 10 Hz-30 kHz
Microphone	+0, -1 dB, 10 Hz-28 kHz
Balanced Input <sup>1</sup>	
Line with 5195 Transformer	+1, -2 dB, 10 Hz-20 kHz
Microphone with 5901 Transformer	+1, -2 dB, 30 Hz-20 kHz

Total Harmonic Distortion<sup>3</sup> 0.2%, 20 Hz-20 kHz @ rated output

#### Intermodulation Distortion<sup>1,4</sup> (SMPTE)

Direct Out	
Direct Input (unbalanced)	
Line	0.005%
Microphone	0.03%
Balanced Input	
Line	0.007%
Microphone	0.06%
Balanced Output	
Direct Input (unbalanced)	
Line	0.0065%
Microphone	0.06%
Balanced Input	
Line	0.0085%
Microphone	0.06%

#### Equivalent Input Noise<sup>3,5</sup>

Direct Input <sup>1</sup>	
Line	-100 dBm
Microphone	-126 dBm

Balanced Input <sup>1</sup>	
Line with 5195 Transformer	-99 dBm
Microphone with 5901 Transformer	133.5 dBm
Compress/Limiter Functions	
Attack Time	
Fast	400 $\mu$ s
Medium	3.0 ms
Slow	140 ms
Release Time	
Fast	30 dB/s
Medium	8 dB/s
Slow	4 dB/s
Controls	
Input 1 & 2	Audio taper, rotary
Output	Audio taper, rotary
Threshold	Audio taper, rotary
Attack	3-position slide switch
	Fast
	Medium
	Slow
Function	3-position slide switch
	Out
	Compress
	Limit
Meter Range	3-position slide switch
	0 dB
	+4 dB
	+8 dB
Meter Select	2-position slide switch gain reduction
	Line out
Microphone Attenuator	3-position slide switch
	0 dB
	-15 dB
	-30 dB
Release	3-position slide switch
	Fast
	Medium
	Slow
Mic 1/Line & Mic 2/Line	Push-lock/push-release
Indicators	
Power On	Green LED
Meter	Illuminated
Power Requirements	
Line Voltage	120/240 V AC, 50/60 Hz
Wattage	15 watts maximum
Connectors	
Line Input(2)	Screw terminal board
Microphone Inputs(2)	Female XL-type socket, positive locking
Output	Screw terminal board
Accessory Transformer	9-pin female socket
Dimensions	
Front Panel	483 mm x 88 mm 19 in x 3 15/32 in
Depth of Controls	19 mm 3/4 in
Depth Behind Panel	178 mm 7 in
Weight	
Net	4 kg 9 lb
Shipping	5.4 kg 12 lb
Mounting	2 EIA standard rack spaces
Panel Finish	Semi-gloss baked enamel, dark gray; white nomenclature
Accessories	
	Model 5195 matching/bridging transformer
	Model 5901 microphone transformer

NOTES: 1. 600  $\Omega$  source.  
2. Measured at 0.5% THD.  
3. ATTACK and RELEASE times set to slow.  
4. At +18 dBm.  
5. Requires a 20 Hz-20 kHz equivalent bandwidth filter.

## Installation

The 7130 is suitable either for rack mounting in two EIA rack spaces without additional bracing or ventilation, or for counter-top placement. A full set of mounting hardware is packaged with each unit. All external connections are made on the rear panel, Figure 2.

## Operating Temperature

The maximum allowable ambient temperature for the 7130 is 60°C (140°F).

## Operating Controls

All operating switches, meter, threshold and level controls, except for MIC/LINE input selector switches, are located on the front panel, Figure 1.

## Input Connections

Input connections to the 7130 may be either direct coupled or transformer isolated at the XL-type sockets or screw terminal boards, Figure 2.

Direct coupling is accomplished by connecting either the center conductor of a shielded cable to **DIRECT** (line input) and the shield to **GND**, or the center conductor of a shielded cable to pin #2 (XL-type connector) and the shield to pin #1.

For transformer isolated inputs, a 5901 universal microphone transformer (for microphone inputs) or a 5195 matching/bridging transformer (for line inputs), Figure 3 and 5, may be used. Transformer isolation is accomplished by connecting the clear conductor of a two conductor shielded cable to **HI** (line input), the black conductor to the **LO** and the shield to **GND**, or the clear conductor of a two conductor shielded cable to pin #3 (XL-type conductor), the black to pin #2 and the shield to pin #1.

## Output Connections

Output connections to the 7130 may be either direct coupled or transformer isolated at the screw terminal board, Figure 2.

Direct coupling is accomplished by connecting the center conductor of a shielded cable to **DIRECT** and the shield to **GND**.

Transformer isolated output is accomplished by connecting the clear conductor of a two conductor shielded cable to the **HI**, the black conductor to the **LO** and the shield to **GND**.

## Installation of Microphone or Line Transformer

To install the optional transformers, Figure 3 or 5, (Model 5195 or 5901):

1. Remove the two copper jumpers between terminals 8 & 9 and 4 & 5.

NOTE: Remove only the jumpers from the 9-pin socket in which the optional transformer is to be used.

2. Install the optional transformer per Figure 4.

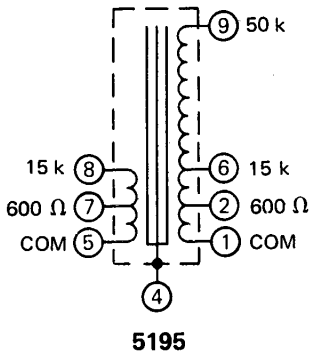

FIGURE 3

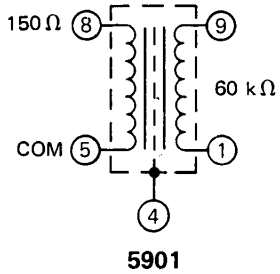
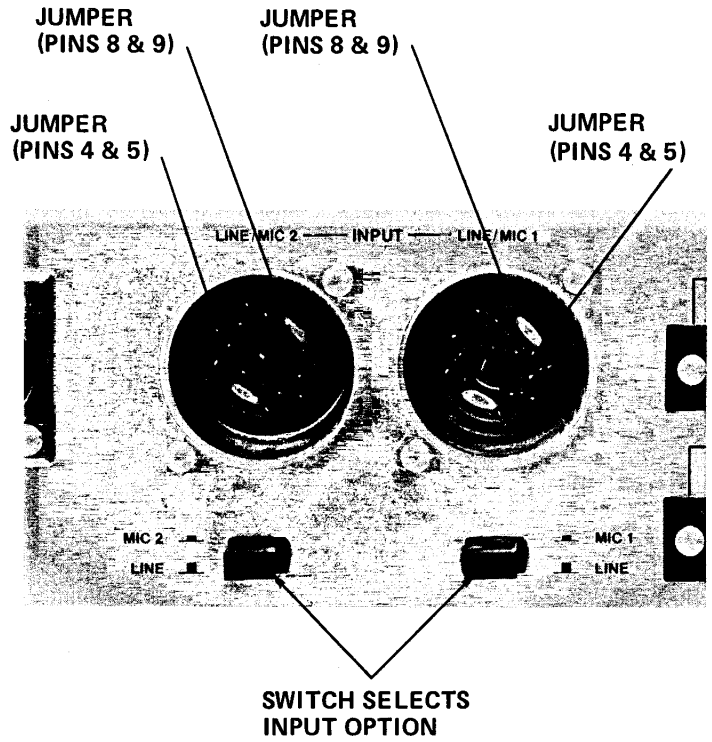
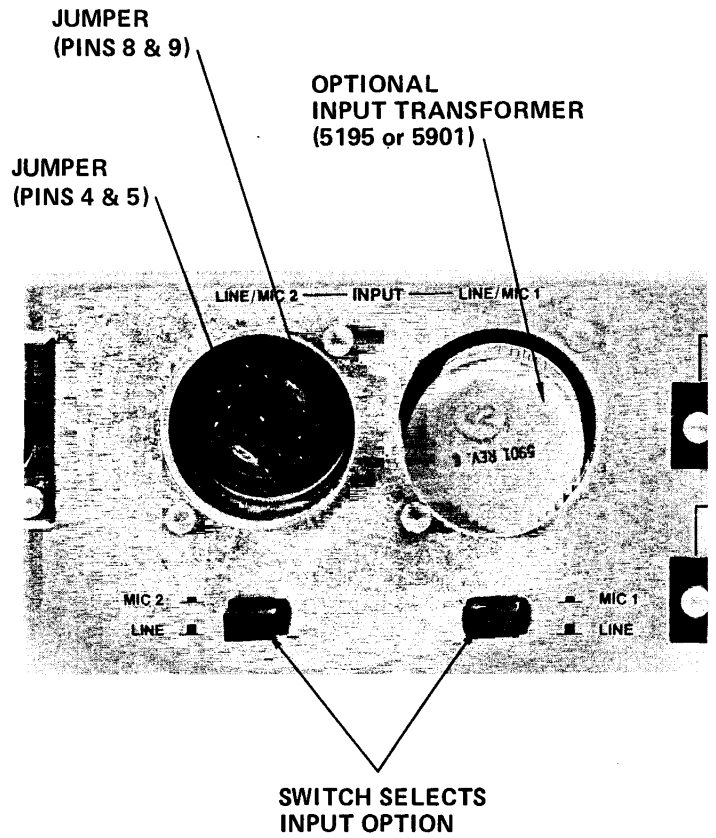

FIGURE 4



**JUMPER INSTALLATION**

1. Remove the optional transformer from the appropriate 9-pin socket.
2. Install two #12 AWG copper jumpers per Figure 6.

**Input 1** Controls either line level or microphone input level depending on position of MIC 1/LINE push-lock/push-release switch.  
 NOTE: When either the JBL 5901 or 5195 transformer is used, the INPUT 1 control cannot be used to prevent transformer saturation if excessive input signal levels occur. See SPECIFICATIONS (Input Characteristics) for maximum input.

**Input 2** Controls either line level or microphone input level depending on position of MIC 1/LINE push-lock/push-release switch.  
 NOTE: When either the JBL 5901 or 5195 transformer is used, the INPUT 2 control cannot be used to prevent transformer saturation if excessive input signal levels occur. See SPECIFICATIONS (Input Characteristics) for maximum input.

**Output** Provides simultaneous attenuation of all input channels using a continuously variable potentiometer marked from 0 to 10.

**Attack** Selects one of three fixed attack times:  
 Fast ..... 400  $\mu$ s  
 Medium ..... 3.0 ms  
 Slow ..... 140ms

**Function Compress Out** Selects any one of three optional modes of 7130

**Meter Select Gain Reduction Line Out** Selects VU meter function.

**Threshold** Adjustable control which sets the level above which compression or limiting occurs.

**Power Switch Push-Lock/ Push-Release** Applies power to 7130.

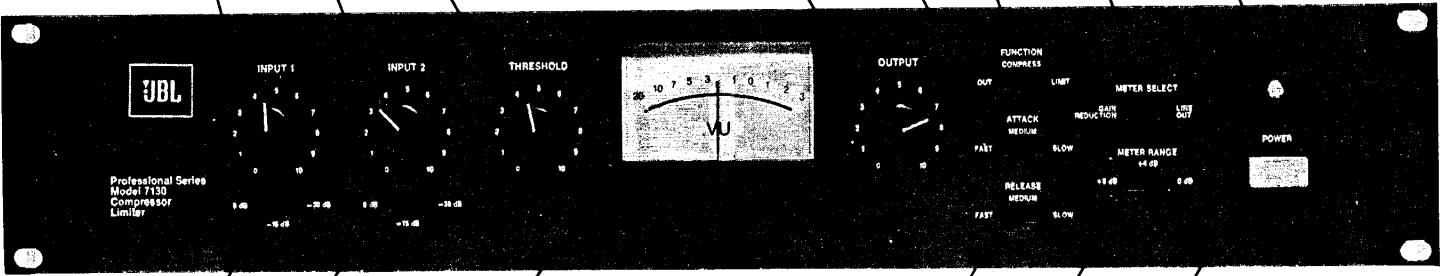

**MIC Attenuator Pad Switches**  
 0 dB -30 dB  
 -15 dB  
 Reduces gain 15 dB or 30 dB on corresponding microphone input channels to allow the use of high-impedance microphones without introducing distortion.  
 NOTE: The mic attenuator pad changes the feedback in the input stage; it can not be used to prevent input saturation if excessive input signal levels occur, but does not effect possible saturation of optional 5901 universal input transformer.

**VU Meter** Displays either output or gain reduction in volume units (VU). Meter is illuminated when secondary voltage is applied.

**Release** Selects one of three fixed release times:  
 Fast ..... 400  $\mu$ s  
 Medium ..... 3.0 ms  
 Slow ..... 140ms

**Meter Range** Selects full-scale range of meter. Calibrated as follows:

METER RANGE	METER DISPLAY	OUTPUT REF. $\Omega$	OUTPUT VOLTAGE
0 dBm	0	0 dBm	0.775 V
+4 dBm	0	+4 dBm	1.129 V
+8 dBm	0	+8 dBm	1.948 V

**LED Power On Indicator Light** Indicates power applied to unit.

FIGURE 7

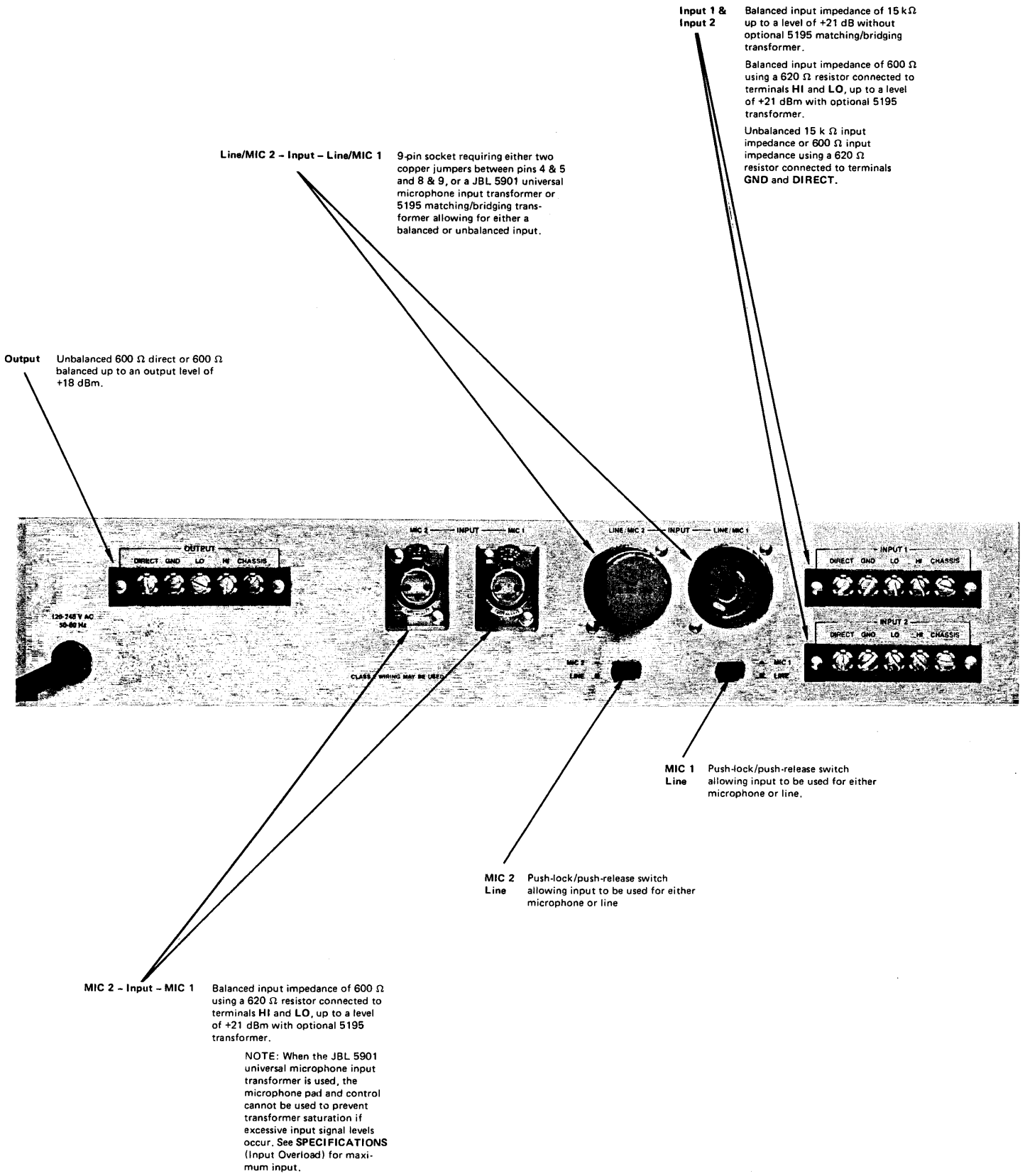
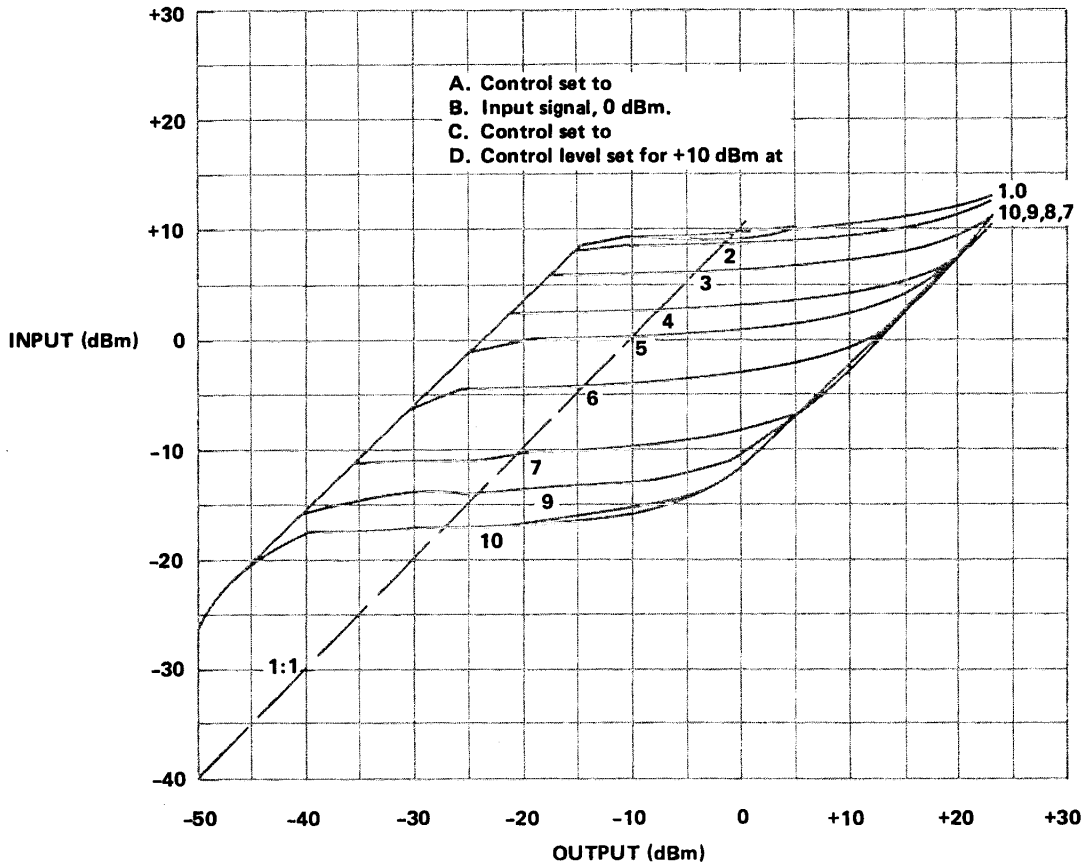
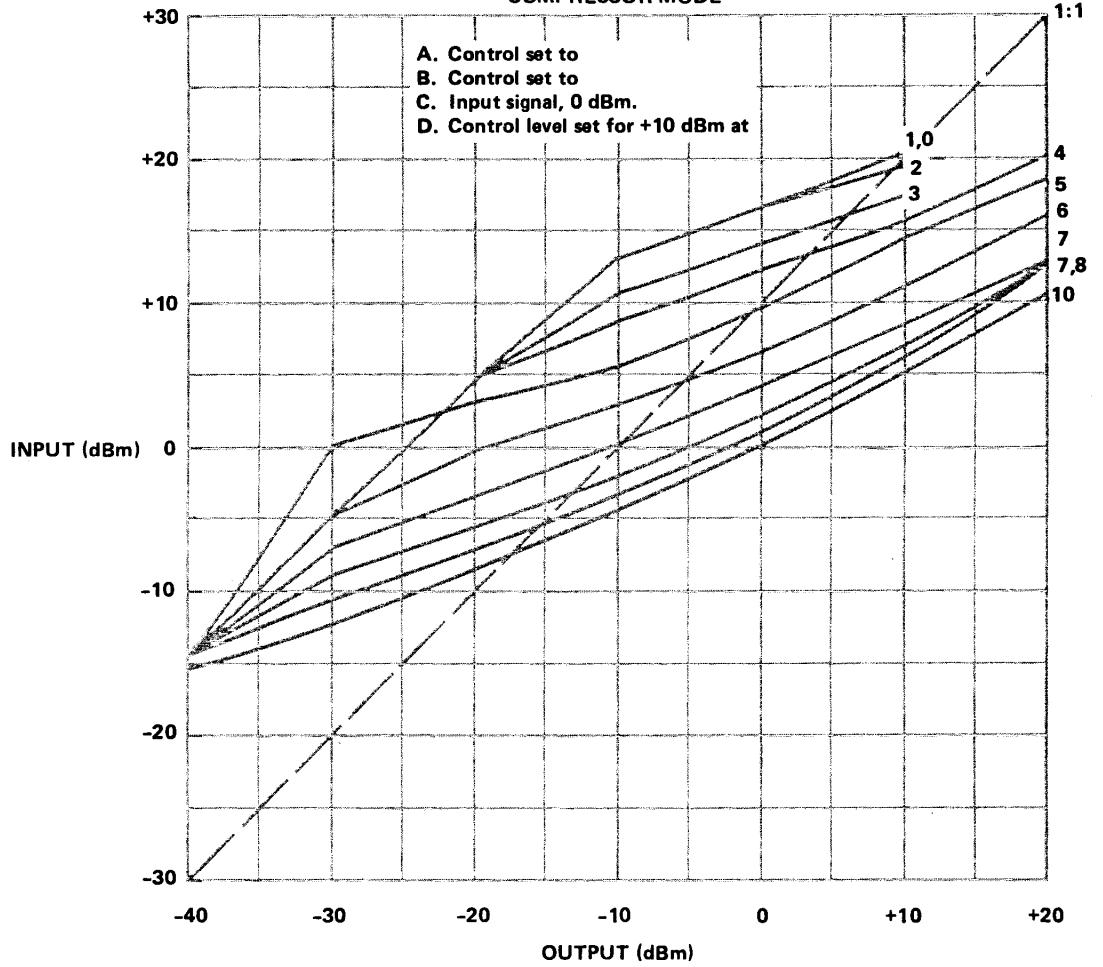

FIGURE 2

**LIMITER MODE**



**COMPRESSOR MODE**



**WARNING**  
 THIS SECTION OF THE MANUAL  
 CONTAINS SERVICE INSTRUCTIONS  
 FOR USE BY QUALIFIED SERVICE  
 PERSONNEL ONLY.

**Service and Maintenance Instructions**

The following procedures are designed to assist in the isolation of malfunctions. The operations described should be undertaken only after an investigation of all external connections and adjustments has indicated, beyond reasonable doubt, that the problem is actually internal.

**WARNING:** Disconnect the 7130 from the power source before performing service operations or replacing components.

**Voltage Conversion**

The 7130 can be operated from either 120 V AC or 240 V AC, 50/60 Hz source. The line voltage selector, a Molex commoning connector, Figure 7, changes the primary connections of the power transformer. Use the following procedure to change the voltage range:

1. Remove the four screws which hold the top cover to the chassis.
2. To convert from 120 V AC to 240 V AC, remove only the following wires, shown in Figure 8 and Table 2:
3. Remove the frosted spacers from the commoning connector, spaces 7 and 8.
4. Insert the two colored coded wires removed from step 2, Table 2 and insert them per Figure 9, Table 3:



FIGURE 7

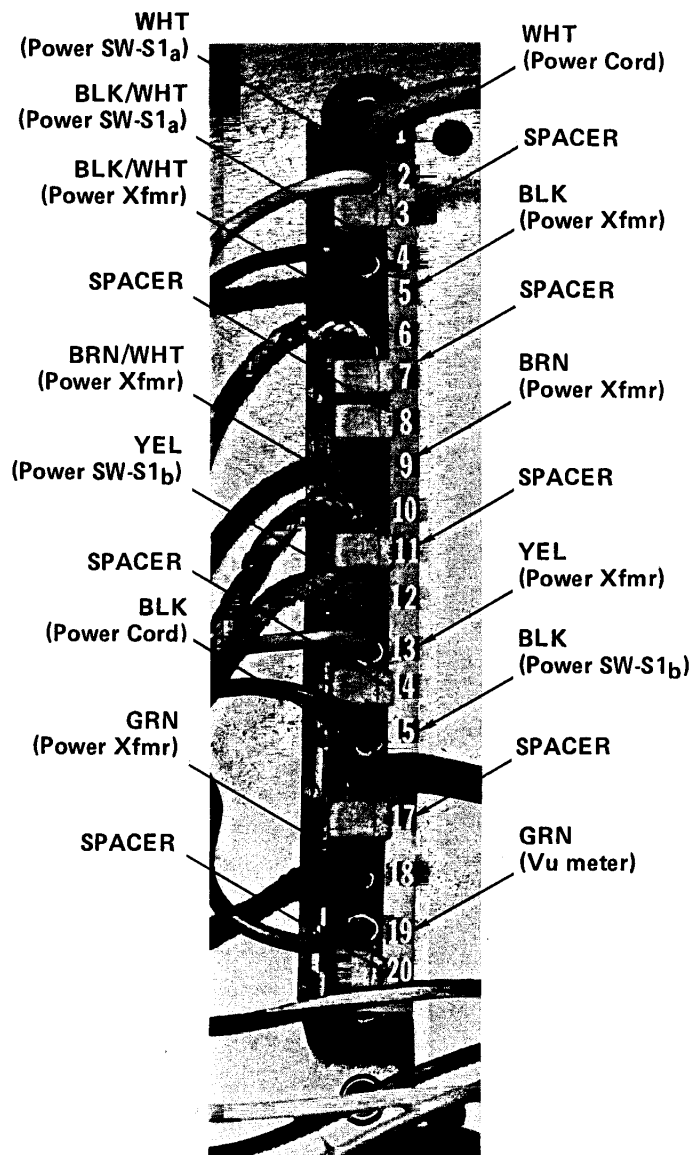

FIGURE 8



**WARNING**  
THIS SECTION OF THE MANUAL  
CONTAINS SERVICE INSTRUCTIONS  
FOR USE BY QUALIFIED SERVICE  
PERSONNEL ONLY.

**TABLE 2 (120 V AC commoning wire code)**

Commoning Connector Terminal	Wire Color	Wire Origin	Spacer Required
1	Wht	Power Cord	
2	Wht	Power Switch	
3			Yes
4	Blk/Wht	Power Switch	
5	Blk	Power Transformer	
>6	Blk/Wht	Power Transformer	<
7			Yes
8			Yes
>9	Brn	Power Transformer	<
10	Brn/Wht	Power Transformer	
11			Yes
12	Yel	Power Switch	
13	Yel	Power Transformer	
14			Yes
15	Blk	Power Switch	
16	Blk	Power Cord	
17			Yes
18	Grn	Power Transformer	
19	Grn	Meter/LED Assy.	
20			Yes

NOTE: > & < denotes commoning connector terminal changes required to change line voltage from 120 V AC to 240 V AC. See Table 3 and manual instructions for correct procedures.

**TABLE 3 (240 V AC commoning wire code)**

Commoning Connector Terminal	Wire Color	Wire Origin	Spacer Required
1	Note 1.	Power Cord	
2	Wht	Power Switch	
3			Yes
4	Blk/Wht	Power Switch	
5	Blk	Power Transformer	
6			Yes
>7	Blk/Wht	Power Transformer	<
>8	Brn	Power Transformer	<
9			Yes
10	Brn/Wht	Power Transformer	
11			Yes
12	Yel	Power Transformer	
13	Yel	Power Switch	
14			Yes
15	Blk	Power Switch	
16	Note 1.	Power Cord	
17			Yes
18	Grn	Power Transformer	
19	Grn	Meter/LED Assy.	
20			Yes

NOTES:  
1. Based on local regulations.  
2. > & < denotes commoning connector terminal changes required to change line voltage from 240 V AC to 120 V AC. See Table 2 and manual instructions for correct procedures.

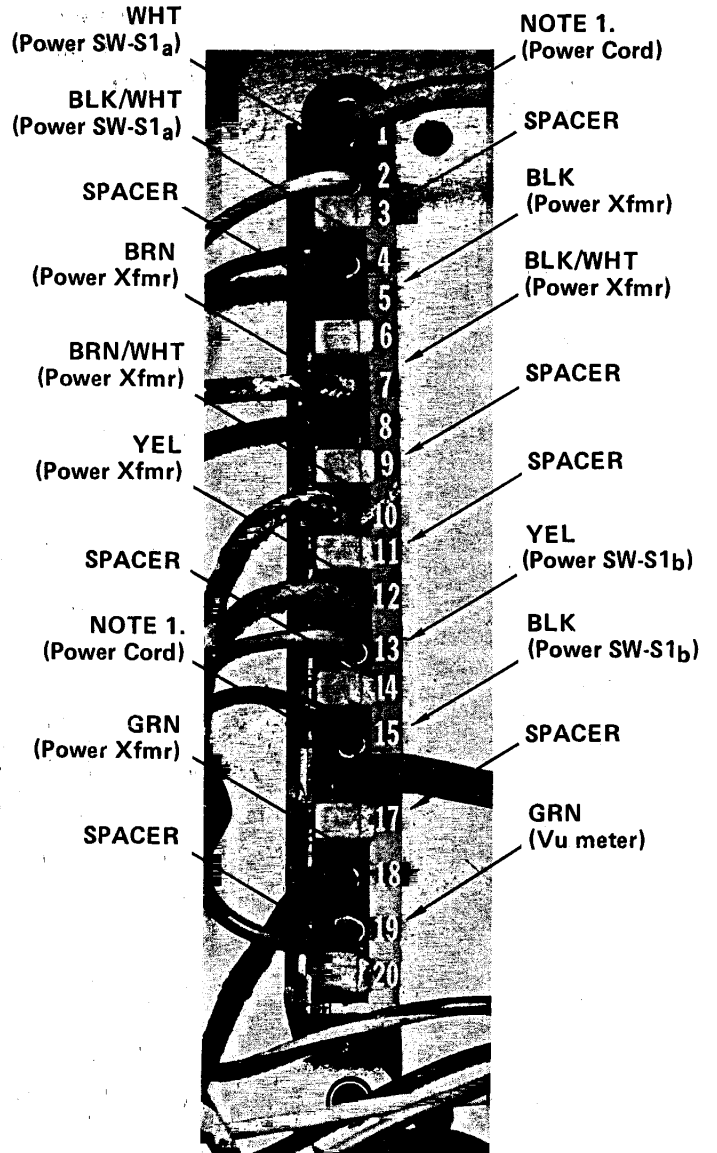

NOTE 1. Based on local regulations.

**FIGURE 9**

**WARNING**  
THIS SECTION OF THE MANUAL  
CONTAINS SERVICE INSTRUCTIONS  
FOR USE BY QUALIFIED SERVICE  
PERSONNEL ONLY.

5. Insert the frosted spacers into spaces 6 and 9.
6. Change the line cord and/or attachment plug to match the supply source receptacle, or use a 120 V to 240 V AC adapter (not provided). The adapter as well as the power supply cord/or attachment plug used for 240 V AC mode in the U.S., Canada and Japan shall be both UL listed and CSA certified for use with said power source receptacle and wired per Table 3. For use in other countries, adapter, line cord and/or attachment plug selection shall be based on local regulations.
7. In countries requiring line cords having wire codes different from those noted in Step #6, the following suggestions apply.
  - A. Remove the existing power cord from the chassis, and be careful not to damage the Molex crimp terminal. If a new Molex crimp terminal is not available, follow steps B through H. If a Molex 1457-1 is available, follow steps I through M.
  - B. Cut the existing single wire of the power cord having the Molex crimp terminal 38 mm (1.5 in). Strip the cut end of the wire 5 mm (3/16 in) and tin.
  - C. Obtain an Electrovert single strip, 6E/1 DS or equivalent.
  - D. Using the original power cord as a wire guide, strip the outer covering from the new power cord and cut each wire to the appropriate length, per the local wiring code.
  - E. Strip 5 mm (3/16 in) from the longest wire and tin.
  - F. Insert the wires from steps B and E into the Electrovert terminal strip and tighten as required.
  - G. Solder the appropriate colored ground wire to solder lug E1.
  - H. Insert the crimped Molex terminals into the Molex commoning connector, spaces #1 and #16. Verify that the remaining transformer crimp terminals and spacers have been changed for 240 V AC use, per Table 3.
  - I. Using the existing power cable as a wire length guide, strip the outer covering of the new power cord and cut each wire to length per the local wiring code.
  - J. Strip 3 mm (1/8 in) from the longest wire.
  - K. Insert the wire into the Molex terminal per Figure 7, and crimp, using a Molex tool model HTR 1031C or equivalent.
  - L. Solder the appropriate colored ground wire to solder lug E1.
  - M. Insert the crimped Molex terminals into the Molex commoning connector, spaces #1 and #16. Verify that the remaining transformer crimp terminals and spacers have been changed for 240 V AC use, per Table 3.

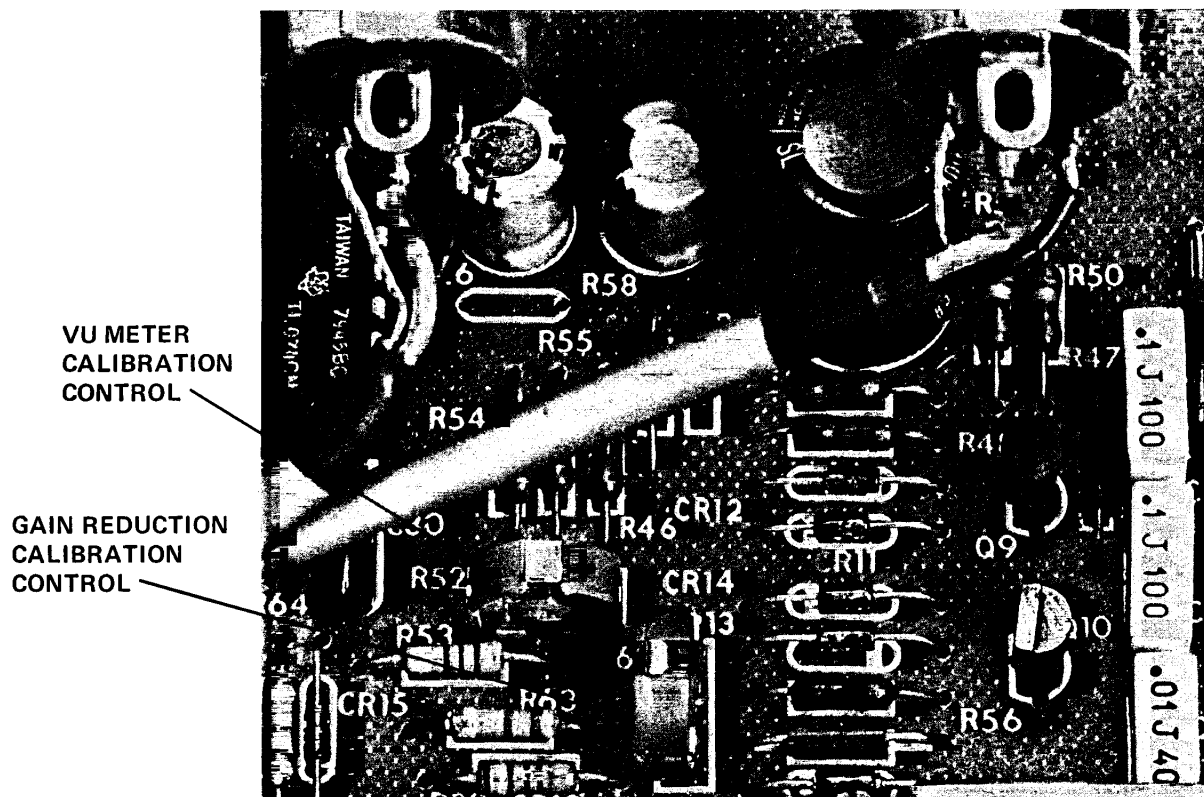

FIGURE 10

**WARNING**  
 THIS SECTION OF THE MANUAL  
 CONTAINS SERVICE INSTRUCTIONS  
 FOR USE BY QUALIFIED SERVICE  
 PERSONNEL ONLY.

**VU Meter Calibration Procedure**

1. Remove the top cover.
2. Connect an AC voltmeter to the OUTPUT screw terminal board **DIRECT** and **GND** and terminate with a 600  $\Omega$  load.
3. Connect a test oscillator's 600  $\Omega$  output, terminated by a 600  $\Omega$  load, to **LINE 1** screw terminal board **DIRECT** and **GND**.
4. Set the 7130 controls as follows:
 

Input 1 .....	Max
Output .....	Max
Function .....	Out
Meter Range .....	dB
Meter Select .....	Line out
5. Set the test oscillator frequency to 1 kHz at an amplitude of -31 dBm.
6. Adjust the meter calibration control, R52, Figure 10, for 0 VU indication, 0 dBm.

**Gain Reduction, 0 VU Meter Calibration**

1. Remove the top cover.
2. Set the 7130 controls as follows:
 

Input 1 & 2 .....	Minimum
Threshold .....	Minimum
Output .....	Minimum
Meter Select .....	Gain reduction
3. Adjust R62, Figure 10, for 0 VU.

**Compress/Limit Adjustment**

1. Remove the top cover.
2. Connect the AC voltmeter to the **OUTPUT** screw terminal board, **DIRECT** and **GND** and terminate with a 600  $\Omega$  load.
3. Connect the test oscillator's 600  $\Omega$  output, terminated by 600  $\Omega$  load, to **LINE 1** screw terminal board **DIRECT** and **GND**.
4. Set the 7130 controls as follows:
 

Input 1 .....	Max
Threshold .....	Max
Output .....	Max
Attack .....	Fast
Release .....	Fast
Function .....	Compress
5. Set the test oscillator frequency to 1 kHz at an amplitude of +10 dBm.
6. Adjust R3, Figure 11, for 2.7 V AC.
7. Reset the **THRESHOLD** control to minimum.
8. Adjust the oscillator output level until the output level of the 7130 is +20 dBm. Input level to the 7130 must measure -7 dBm,  $\pm 3$  dBm.
9. Set the Function switch to **LIMIT** and the **THRESHOLD** control to maximum.
10. Adjust the oscillator for 0 dBm output of the 7130. Input to the 7130 should read -6 dBm,  $\pm 3$  dBm.
11. Turn the **THRESHOLD** control to minimum. Output of the 7130 must read +16 dBm,  $\pm 2$  dBm.

R3  
 GAIN TRIM  
 ADJUSTMENT

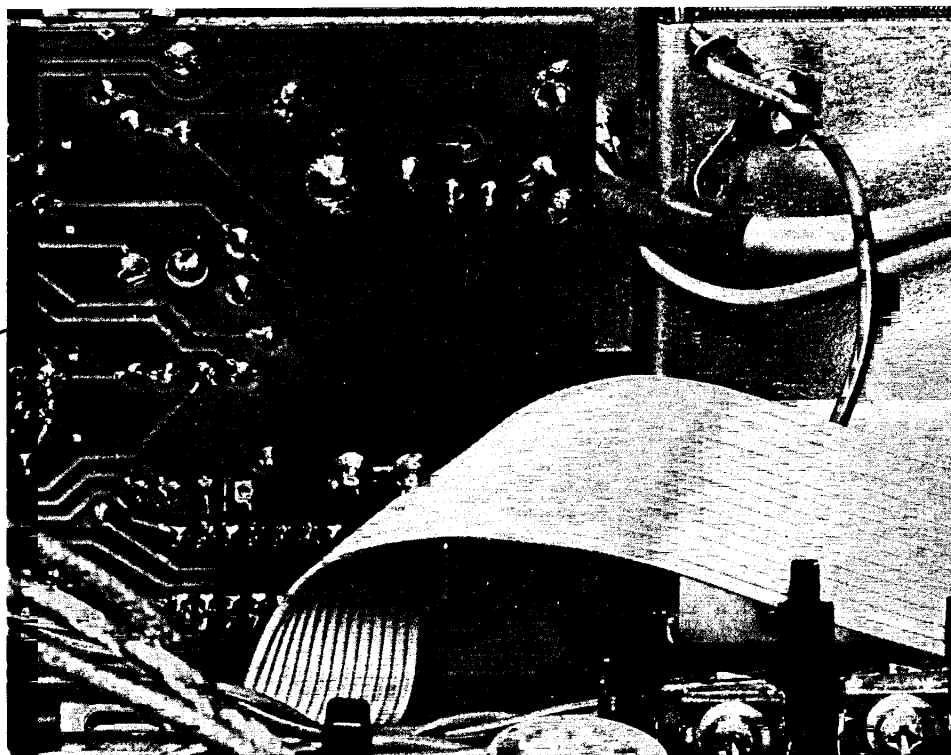
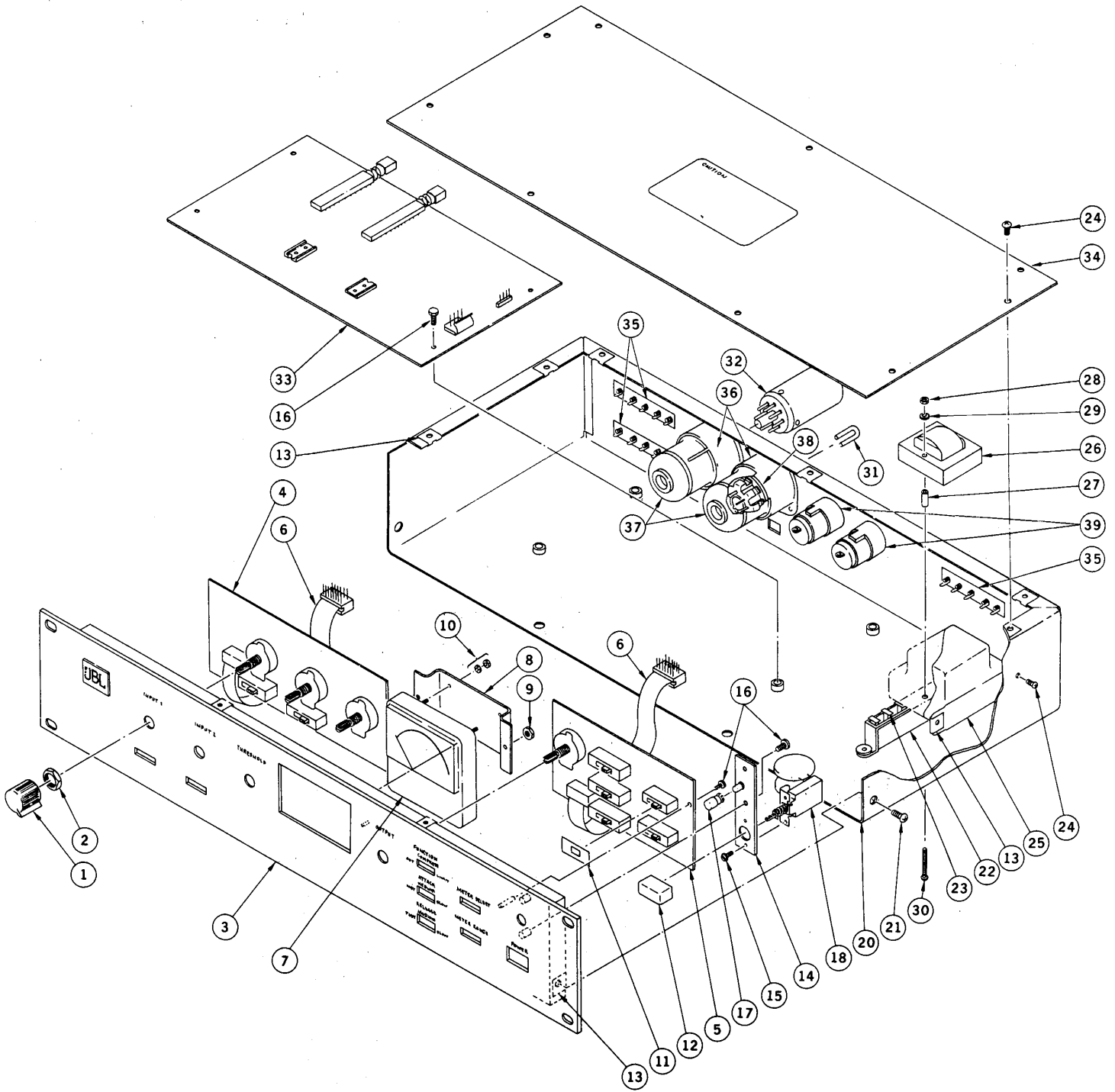

FIGURE 11

**WARNING**  
THIS SECTION OF THE MANUAL  
CONTAINS SERVICE INSTRUCTIONS  
FOR USE BY QUALIFIED SERVICE  
PERSONNEL ONLY.



**7130 Exploded View and Parts List**

FIGURE 13.

**WARNING**  
**THIS SECTION OF THE MANUAL**  
**CONTAINS SERVICE INSTRUCTIONS**  
**FOR USE BY QUALIFIED SERVICE**  
**PERSONNEL ONLY.**

Item	JBL Part No.	Qty	Description
1	55630	4	Knob
2	—	4	Part of board assy.
3	59295	1	Front panel
4	59309	1	PC board assy.
5	59311	1	PC board assy.
6	59315-01	2	Flat ribbon assy.
7	55098	1	Meter
8	59291	1	Meter bracket
9	89508	2	6-32 Keps nut
10	Note <sup>1</sup>	4	Meter mounting set
11	58469	7	Glamour shield
12	54969	1	Knob
13	59827	17	#6 speed washer
14	59933-01	1	PC board assy.
15	47631	2	4-40 x 1/4 binding head screw
16	47896	7	6-32 x 5/16 hex head screw
17	59893	1	Green LED lens
18	54953	1	Power switch
19	13189	2	Capacitor
20	59294	1	Chassis

Item	JBL Part No.	Qty	Description
21	89654	6	6 x 3/8 hex washer screw
22	59303	1	Commoning connector
23	59305	5	Polarizing key
24	59848	11	6 x 3/8 Phillips-head screw
25	59306	1	Power transformer
26	59299	1	Output transformer
27	57806	2	Spacer
28	11496	2	4-40 hex-nut
29	12267	2	#4 lock washer
30	57807	2	4-40 x 1/4 pan head screw
31	58325-01	4	Jumper
32	—	2	5195 or 5901 transformer
33	59313	1	PC board assy.
34	59293	1	Cover
35	82706	3	Terminal strip
36	55107	2	Recess shell
37	59330	2	Plug assy.
38	55106	2	9 pin socket
39	47600	2	XLR-type socket

Note: 1. 3mm set.

**WARNING**  
 THIS SECTION OF THE MANUAL  
 CONTAINS SERVICE INSTRUCTIONS  
 FOR USE BY QUALIFIED SERVICE  
 PERSONNEL ONLY.

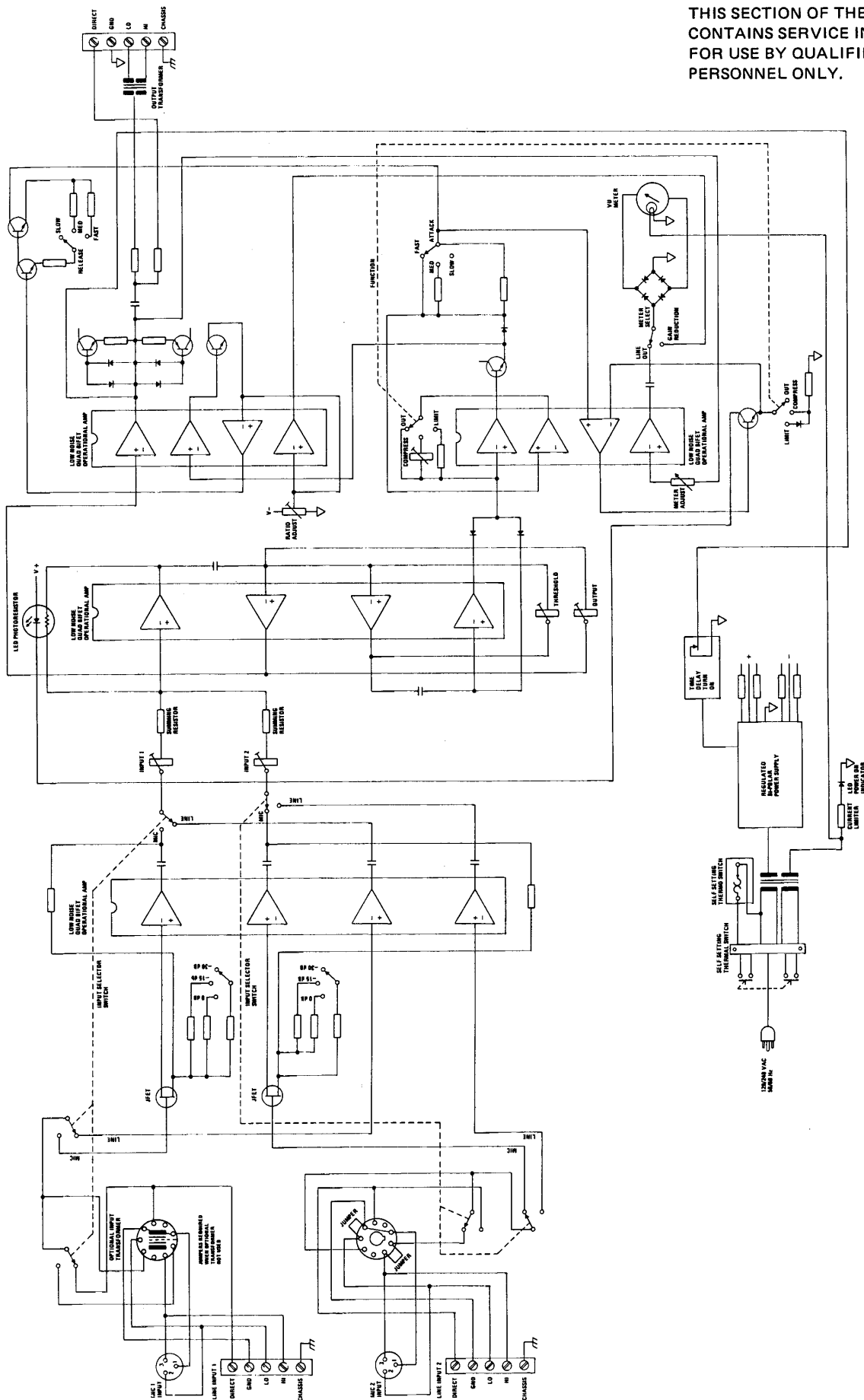

Block Diagram

**WARNING**  
THIS SECTION OF THE MANUAL  
CONTAINS SERVICE INSTRUCTIONS  
FOR USE BY QUALIFIED SERVICE  
PERSONNEL ONLY.

**Test Equipment Required To Meet Proof of Performance:<sup>1</sup>**

Clarostat 240C . . . . .	Decade resistance box
Dana 170 . . . . .	Amplifier
Fluke 8000A . . . . .	DVM
GenRad W5MT3W . . . . .	Variable transformer
GenRad 1523/1523P2 . . . . .	Graphic level recorder set
GenRad 1840-A . . . . .	Output power meter
HP 350B . . . . .	Attenuator set
HP 339A . . . . .	Distortion measurement set
HP 400 FL . . . . .	AC voltmeter
Krohn-Hite 3202 . . . . .	Filter <sup>2</sup>
Philips PM3262 . . . . .	Dual trace scope
Sound Technology 1770B . . . . .	IM distortion measurement set
Tektronix 7000 series . . . . .	Storage oscilloscope

- Notes: 1. Equivalent test equipment may be substituted.  
2. 20 kHz equivalent bandwidth filter.